

(12) INTERNATIONAL APPLICATION PUBLISHED UNDER THE PATENT COOPERATION TREATY (PCT)

(19) World Intellectual Property Organization  
International Bureau



(43) International Publication Date  
21 December 2000 (21.12.2000)

PCT

(10) International Publication Number  
WO 00/76673 A1

- (51) International Patent Classification<sup>7</sup>: B05B 7/00 (74) Agent: BOZICEVIC, Kart; Bozicevic, Field & Francis LLP, Suite 200, 200 Middlefield Road, Menlo Park, CA 94025 (US).
- (21) International Application Number: PCT/US00/15931
- (22) International Filing Date: 9 June 2000 (09.06.2000) (81) Designated States (*national*): AE, AG, AL, AM, AT, AU, AZ, BA, BB, BG, BR, BY, CA, CH, CN, CR, CU, CZ, DE, DK, DM, DZ, EE, ES, FI, GB, GD, GE, GH, GM, HR, HU, ID, IL, IN, IS, JP, KE, KG, KP, KR, KZ, LC, LK, LR, LS, LT, LU, LV, MA, MD, MG, MK, MN, MW, MX, MZ, NO, NZ, PL, PT, RO, RU, SD, SE, SG, SI, SK, SL, TJ, TM, TR, TT, TZ, UA, UG, US, UZ, VN, YU, ZA, ZW.
- (25) Filing Language: English
- (26) Publication Language: English
- (30) Priority Data: 60/138,698 11 June 1999 (11.06.1999) US (84) Designated States (*regional*): ARIPO patent (GH, GM, KE, LS, MW, MZ, SD, SL, SZ, TZ, UG, ZW), Eurasian patent (AM, AZ, BY, KG, KZ, MD, RU, TJ, TM), European patent (AT, BE, CH, CY, DE, DK, ES, FI, FR, GB, GR, IE, IT, LU, MC, NL, PT, SE), OAPI patent (BF, BJ, CF, CG, CI, CM, GA, GN, GW, ML, MR, NE, SN, TD, TG).
- (71) Applicant (*for all designated States except US*): ARADIGM CORPORATION [US/US]; 3929 Point Eden Way, Hayward, CA 94545 (US).
- (72) Inventors; and
- (75) Inventors/Applicants (*for US only*): ROSELL, Joan [ES/US]; 2250 Vegas Avenue, Castro Valley, CA 94546 (US). GANAN-CALVO, Alfonso [ES/ES]; Camilo Jose Cela, 4, bloque 8, 3<sup>a</sup> A, E-41018 Sevilla (ES).
- Published:  
— With international search report.
- For two-letter codes and other abbreviations, refer to the "Guidance Notes on Codes and Abbreviations" appearing at the beginning of each regular issue of the PCT Gazette.*

(54) Title: METHOD FOR PRODUCING AN AEROSOL

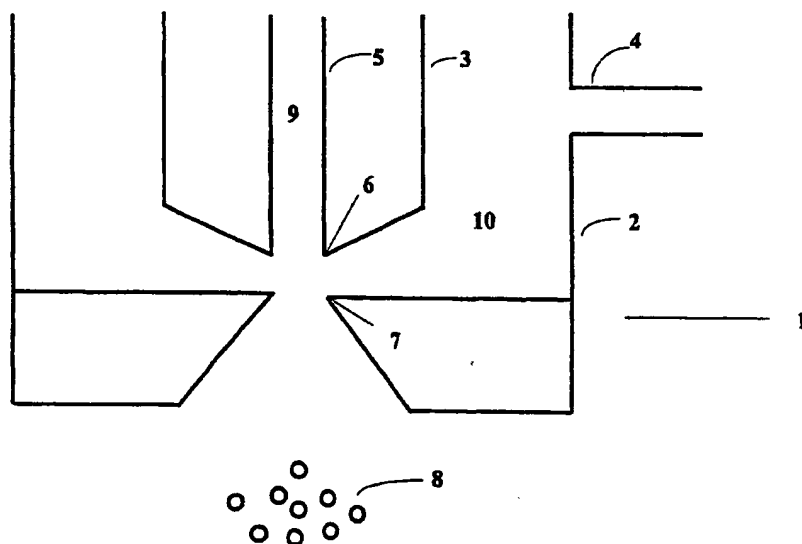

(57) Abstract: A method of creating small particles by a technology referred to here as "violent focusing" is disclosed, along with devices for generating such violent flow focusing. In general, the method comprises the steps of forcing a liquid (9) out of the exit opening (6) of the feeding tube (5) to create a liquid stream. The exit opening (6) is positioned such that the liquid (9) flowing out of the tube (5) flows toward and out of an exit orifice (7) of a pressure chamber (10) which surrounds the exit opening (6) of the feeding tube (5). The liquid flow is broken into particles (18) which have dimensions which are smaller than the dimensions of the liquid stream.

WO 00/76673 A1

## METHOD FOR PRODUCING AN AEROSOL

5

## FIELD OF THE INVENTION

This application generally relates to the creation of an aerosol created by the directed flow of fluids.

10

## BACKGROUND OF THE INVENTION

Devices for creating finely directed streams of fluids and/or creating aerosolized particles of a desired size are used in a wide range of different applications, such as, for example, finely directed streams of ink for ink jet printers, or directed streams of solutions containing biological molecules for the preparation of microarrays. The production of finely dispersed aerosols is also important for (1) aerosolized delivery of drugs to obtain deep even flow of the aerosolized particles into the lungs of patients; (2) aerosolizing fuel for delivery in internal combustion engines to obtain rapid, even dispersion of any type of fuel in the combustion chamber; or (3) the formation of uniform sized particles which themselves have a wide range of uses including (a) making chocolate, which requires fine particles of a given size to obtain the desired texture or "mouth feel" in the resulting product, (b) making pharmaceutical products for timed release of drugs or to mask flavors and (c) making small inert particles which are used as standards in tests or as a substrate onto which compounds to be tested, reacted or assayed are coated.

25

## SUMMARY OF THE INVENTION

A method of creating small particles and aerosols by a technology referred to here as "violent focusing" of a liquid to break up and disperse a liquid is disclosed, along with devices for generating such violent flow focusing. In general, a "violent focusing" method comprises the steps of forcing a first liquid through a feeding tube and out of an exit opening of the feeding tube is positioned inside a pressure chamber which is continually filled with a second fluid which may be a second liquid immiscible in the first liquid or a gas. The exit

opening of the feeding tube is positioned such that the liquid flowing out of the tube flows toward and out of an exit or discharge orifice of the chamber surrounding the exit opening of the feeding tube. The first liquid exiting the tube is focused to a substantially reduced diameter and subjected to a violent action created by the second liquid or gas, breaking up  
5 the flow into particles substantially smaller than if the reduced diameter flow underwent spontaneous capillary breakup. The exit opening of the feeding tube preferably has a diameter in the range of about 5 to about 10,000 microns and the exit opening of the tube is positioned at a distance in a range of from about 5 to about 10,000 microns, more preferably about 15 to about 200 microns from an entrance point of the exit orifice.

10 A stream of the first liquid flows out of the tube and is focused by the flow of the second liquid or gas in the surrounding pressure chamber. The focused stream then exits out of the discharge orifice of the pressure chamber, destabilizing and forming small particles. The size of the particles of the first liquid is governed by the balance between the surface tension forces of the first liquid particle formed, and the amplitude of the turbulent pressure  
15 fluctuations at, and outside of the exit orifice of the pressure chamber. When the particles are sufficiently small that their surface tension forces substantially match the amplitude of the pressure fluctuation then the particles are stabilized and will not break up into still smaller particles.

## 20 BRIEF DESCRIPTION OF THE DRAWINGS

Figure 1 is a schematic cross-sectional plan view of a nozzle of the invention;

Figure 2 is another embodiment of the nozzle of Figure 1 showing and labeling various angles and areas of the nozzle;

25 Figure 3 is the same embodiment as shown in Figure 1 with various angles and areas labeled;

Figure 4 is another embodiment of the nozzle of Figure 1 with certain areas and angles labeled;

Figure 5 is an embodiment of the nozzle of Figure 1 with various parameters labeled;

Figure 6 is a graph of the volume median diameter (VMD) vs the liquid supply flow rate for four different liquids;

Figure 7 is a graph of the dimensionless volume median diameter (VMD) versus dimensionless liquid flow rate with a line through the data points showing the best power-fit;

5 Figure 8 is a graph of the data with the line shown in Figure 7 compared to a theoretical line for the Rayleigh breakup prediction of a flow-focused jet; and

Figure 9 is a graph of data obtained with the different liquids listed of the geometric standard deviation (GSD) vs. dimensionless liquid flow rates.

#### 10 DETAILED DESCRIPTION OF PREFERRED EMBODIMENTS

Before the present aerosol device and method are described, it is to be understood that this invention is not limited to the particular components and steps described, as such may, of course, vary. It is also to be understood that the terminology used herein is for the purpose of describing particular embodiments only, and is not intended to be limiting, since  
15 the scope of the present invention will be limited only by the appended claims.

It must be noted that as used herein and in the appended claims, the singular forms "a", "and," and "the" include plural referents unless the context clearly dictates otherwise. Thus, for example, reference to "a particle" includes a plurality of particles and reference to "a fluid" includes reference to a mixture of fluids, and equivalents thereof known to those  
20 skilled in the art, and so forth.

Unless defined otherwise, all technical and scientific terms used herein have the same meaning as commonly understood by one of ordinary skill in the art to which this invention belongs. Although any methods and materials similar or equivalent to those described herein can be used in the practice or testing of the present invention, the preferred  
25 methods and materials are now described. All publications mentioned herein are incorporated herein by reference in their entirety to disclose and describe the methods and/or materials in connection with which the publications are cited.

The publications discussed herein are provided solely for their disclosure prior to the filing date of the present application. Nothing herein is to be construed as an admission  
30 that the present invention is not entitled to antedate such publication by virtue of prior

invention. Further, the dates of publication provided may be different from the actual publication dates which may need to be independently confirmed.

#### GENERAL METHODS

5           The method is carried out by forcing a liquid from a liquid supply means, e.g. a tube. The liquid exits the supply means into a pressure chamber filled with a second fluid which is preferably a gas. The chamber has an exit port preferably positioned directly in front of and preferably downstream of the flow of liquid exiting the supply means. The exit port may be positioned slightly upstream of the liquid supply means exit. The liquid is  
10 focused by the gas to substantially smaller dimensions as it exits the supply means e.g. a tubular stream of liquid one unit in diameter is focused to a stream  $1/2 - 1/400$  of a unit in diameter or smaller depending on operating conditions. In this proposed example, a focused cylindrical stream of one unit in diameter would be expected to undergo Rayleigh breakup and form particles which are about 1.89 times the diameter of the focused stream. However,  
15 by correctly adjusting parameters (such as positioning the exit of the liquid supply means relative to the chamber exit port) the liquid stream is first focused by the gas flowing out of the chamber thereby forming a stream with a much smaller diameter. That stream leaves the chamber and forms particles which are smaller in diameter than the focused stream.

          Based on the above it will be understood that the nozzles and methods of the  
20 present invention are capable of producing extremely small particles. As an example, consider producing particles using a cylindrical liquid supply means having a diameter of 1000 units. The stream from such a supply means would be expected to undergo normal Rayleigh breakup of the 1000 unit diameter stream to form spherical particles having a diameter of about  $1.89 \times 1000$  or 1890 units in diameter. If the stream having a diameter of  
25 1000 units is focused to a stream or jet of smaller dimension by a surrounding gas the jet might have a diameter of one tenth that size or 100 units. That 100 unit diameter focused jet would be expected to undergo normal Rayleigh breakup to form particles having a diameter of  $1.89 \times 100$  or 189 units.

          Focusing the diameter of the stream to a narrow focused jet or "stable microjet" jet  
30 has been referred to as flow focusing technology. When using the flow focusing technology

the focused jet has a diameter  $d_j$  at a given point A in the stream characterized by the formula:

5 
$$d_j = \left( \frac{8 \rho_l}{\Pi^2 \Delta P_g} \right)^{1/4} Q^{1/2},$$

wherein  $d_j$  is the diameter of the stable microjet,  $\approx$  indicates approximately equally to where an acceptable margin of error is  $\pm 10\%$ ,  $\rho_l$  is the density of the liquid and  $\Delta P_g$  is change in gas pressure of gas surrounding the stream at the point A. The diameter of the jet ( $d_j$ ) can be  
 10 any reduced dimension smaller than that of liquid stream exiting the supply means, e.g. can have a cross-sectional diameter of from about one half to about 1/100 the area of the stream exiting the liquid supply means.

In accordance with the violent flow focusing of the present invention the liquid flow exiting the supply means with a diameter of 1000 units is focused as it leaves the  
 15 supply means so that the end of the exiting drop exiting the liquid supply tube is focused by the surrounding gas to a reduced dimension (e.g. 1/2 to 1/100 the cross-sectional diameter of the liquid supply means). For purposes of example we will say the 1000 unit stream is reduced to a diameter of about 100 units. That 100 unit end of the drop is subjected to turbulent action by the gas exiting the pressure chamber thereby forming particles which are  
 20 10 units in diameter. Thus, the above proposed examples can be summarized as follows:

	Supply Means Diameter	Particle Diameter
Rayleigh	1000	~ 1890
Flow Focusing	1000	~ 189
Violent Flow Focusing	1000	~ 1

25 Based on the above it will be appreciated that the method of the invention can produce particles which are substantially smaller than (e.g. 1/2 to 1/100) the size of particles produced using flow focusing technology. Further, flow focusing technology can produce particles which are substantially smaller than (e.g. 1/2 to 1/100) the size of particles produced  
 30 by normal capillary breakup of a stream.

### GENERAL DEVICE

The basic device or nozzle of the invention can have a plurality of different configurations. However, each configuration or embodiment will comprise a means for supplying a liquid or first fluid and a means for supplying a second fluid (preferably a gas) in a pressure chamber which surrounds at least an exit of the means for supplying a liquid. The liquid supply means and pressure chamber are positioned such that turbulent action takes place between the liquid exiting the liquid supply means and the second fluid, a liquid or a gas, exiting the supply chamber. Preferably, the exit opening of the pressure chamber is downstream of and more preferably it is directly aligned with the flow path of the means for supplying the liquid. To simplify the description of the invention, the means for supplying a liquid is often referred to as a cylindrical tube (tube shape could be varied, e.g. oval, square, rectangular). The first fluid or liquid can be any liquid depending on the overall device which the invention is used within. For example, the liquid could be a liquid formulation of a pharmaceutically active drug used to create dry particles or liquid particles for an aerosol for inhalation or, alternatively, it could be a hydrocarbon fuel used in connection with a fuel injector for use on an internal combustion engine or heater or other device which burns hydrocarbon fuel. Further, for purposes of simplicity, the second fluid is generally described herein as being a gas and that gas is generally air or an inert gas. However, the first fluid is a liquid and the second fluid may be a gas or a liquid provided the first and second fluids are sufficiently different from each other (e.g. immiscible). It is possible to have situations wherein the liquid exits either the liquid supply means or the pressure chamber vaporizes to a gas on exit. Such is not the general situation. Notwithstanding these different combinations of liquid-gas, and liquid-liquid, the invention is generally described with a liquid formulation being expelled from the supply means and interacting with surrounding gas flowing out of an exit of the pressure chamber. Further, the exit of the pressure chamber is generally described as circular in cross-section and widening in a funnel shape (Fig. 1), but could be any configuration.

Referring to the figures a cross-sectional schematic view of the nozzle 1 is shown in Figure 1. The nozzle 1 is comprised of two basic components which include the pressure chamber 2 and the liquid supply means 3. The pressure chamber 2 is pressurized by fluid

flowing into the chamber by the entrance port 4. The liquid supply means 3 includes an inner tube 5 where liquid flows. The inner tube 5 of the liquid supply means 3 is preferably supplied with a continuous stream of a fluid which fluid is preferably in the form of a liquid. The pressure chamber 2 is continuously supplied with a pressurized fluid which may be a liquid or a gas. When the fluid is a liquid the liquid is preferably insoluble and incompatible with the liquid being provided from the inner tube 5 (e.g. oil and water which do not readily mix and form a distinct interface). The inner tube 5 of the liquid supply means 3 includes an exit point 6. The pressurized chamber 2 includes an exit point 7. The exit point 7 of the pressure chamber is preferably positioned directly downstream of the flow of liquid exiting the exit point 6. The liquid supply means exit and the exit of the pressure chamber are configured and positioned so as to obtain two effects (1) the dimensions of the stream exiting the liquid supply means are reduced by the fluid exiting the pressure chamber; and (2) the liquid exiting the liquid supply means and the fluid exiting the pressure chamber undergo a violent interaction to form much smaller particles than would form if the stream of liquid in reduced dimensions underwent normal capillary instability, e.g. formed spherical particles 1.89 times the diameter of the cylindrical stream.

Preferably, the exit port of the chamber 2 is directly aligned with the flow of liquid exiting the liquid supply means 3. An important aspect of the invention is to obtain small particles 8 from the liquid 9 flowing out of the exit port 6 of the inner tube 5. Obtaining the desired formation of particles 8 is obtained by correctly positioning and proportioning the various components of the liquid supply means 3 and the chamber 2 as well as the properties of the fluids including the speed of these fluids which flow out of both the liquid supply means 3 and the chamber 2. Specifically, there are some important geometric parameters that define the nozzle 1 of the present invention. Those skilled in the art will adjust those parameters using the information provided here in order to obtain the most preferred results depending on a particular situation.

Preferably, the liquid 9 is held within the inner tube 5 which is cylindrical in shape. However, the inner tube 5 holding the liquid 9 may be asymmetric, oval, square, rectangular or in other configurations including a configuration which would present a substantially planar flow of liquid 9 out of the exit port 6. Thus, the nozzle of the invention



applies to all kinds of round (e.g., axi-symmetric) and planar (e.g., symmetric two-dimensional) configurations that have a convergent passage for the outer fluid. For example, a round but not axi-symmetric geometry would be one in which the surfaces of the orifice plate are faceted at different azimuthal angles. Accordingly, the figures including Figure 1  
5 are used only to define the variables but are not intended to imply any restrictions on the type of geometry or the specific details of the design of the nozzle 1 of the present invention. There are infinite degrees of freedom of design. For example, corners which are shown as sharp could be rounded or finished in different ways.

Formation of the microjet and its acceleration and ultimate particle formation are  
10 based on the abrupt pressure drop associated with the steep acceleration experienced by the liquid on passing through an exit orifice of the pressure chamber which holds the second fluid (i.e. the gas).

Without being limited to any one theory, the creation of the violently focused aerosol (in an axisymmetric configuration) may occur as follows. The strong radial fluid  
15 flow (10) that exists in the very narrow gap between the points 6 and 7 becomes circulatory as it passes through and out of the orifice of the exit 7 of the pressure chamber 2. At the same time, the liquid (9) meniscus is sucked in towards the center of the exit point 7 of the chamber 2. As the gas 10 exits the hole at point 7, its strong circulatory motion induces the fluid dynamic effect referred to as a vortex breakdown. This is an instability in which fluid  
20 particles gain so much centrifugal inertia that they spin off away from the axis. As a result, a bubble of gas is created along the axis downstream from this point, in which the outer fluid (preferably a gas) flow reverses, flowing upstream back towards the nozzle. Consequently, the droplets are accelerated radially outwards resulting in enhanced dispersion.

Referring now to Figure 2 in order to describe the relationships between some of  
25 the components shown in Figure 1. First, a dashed line C---C' is shown running through the center of the inner tube 5 in which the liquid 9 flows as well as the exit of the chamber 2. In symmetric atomizers the line C--C' represents the plane of symmetry intersection of the plane of view. The line B--B' represents the bisector of the convergent passage near the center of the nozzle. The area referred to as the "convergent passage" is the region which is  
30 the open area between the terminal face 11 of the liquid supply means 3 and the front face 12

of the chamber 2. To obtain desired results with the nozzle of the present invention the following characteristics must be present:

- (a) a strong convergence of the outer fluid (liquid or gas) in the chamber 2 towards and around the inner fluid 9 coming out of the inner tube 5;
- 5 (b) sufficient momentum for the fluid 10 in the chamber 2 before it interacts with the fluid 9;
- (c) a focusing or compression of the stream of liquid 9 by the surrounding fluid 10.

The above characteristics (a)-(c) combine with each and with other characteristics 10 in order to result in the desired (d) vortex breakdown of the stream of fluid 9 exiting the inner tube 5. For example, other characteristics will include sonic speeds and shock waves (e) when the outer fluid 10 is a gas.

In order to more fully understand the invention each of the characteristics (a)-(e) referred to above are described in further detail below.

15

(a) Strong convergence of outer fluid:

The primary characteristic of the present invention is the facilitation of a strongly convergent (imploding) flow of outer fluid 10 towards and around the inner liquid 9. The fluid 10 in the pressure chamber should preferably not merely flow parallel to the liquid 9 exiting the liquid supply means, i.e. should preferably not intersect at a 0 degree angle. 20 Further, the fluid 10 in the pressure chamber should preferably not flow directly perpendicular to the liquid stream 9 exiting the liquid supply means, i.e. should preferably not interact at a 90 degree angle or more. Thus, convergence of the two fluids is preferably at an angle of more than 0 degrees and less than 90 degrees. However, the fluid 10 of the 25 pressure chamber could, in some situations be directed at the liquid 9 from the liquid supply means at an angle of 90 degrees or more, i.e., at an angle such that the fluid 10 is flowing back toward the liquid 9 and is converging on the liquid 9 at an angle of up to 150 degrees.

Flow convergence improves the transfers of momentum and kinetic energy from the outer fluid 10 to the inner liquid 9 required to breakup the inner fluid 9 into particles 8. 30 Improving the efficiency of such transfer results in energy savings for a given amount of

inner liquid 9 atomized and a given droplet size requirement. A greater efficiency of atomization is achieved by transferring a greater fraction of pressure energy originally in the outer fluid 10 per unit mass of the outer fluid to the inner liquid 9.

In order to generate significant convergence in the outer fluid 10 towards the inner liquid 9, the outer fluid 10 must be admitted into a path that gives it a sufficiently high converging speed. Specifically, the following design constraints shown in Figure 3 are preferred.

(1) a convergent passage convergence angle  $\alpha$  smaller than 90 degrees,

$$\alpha < 90 \text{ degrees,}$$

(2) the exterior surface 11 of the feeding passage exit should form an angle  $\beta$  with center line CC' greater than 45 degrees but smaller than 150 degrees,

$$150 \text{ degrees} > \beta > 45 \text{ degrees,}$$

and (3) the length of the convergent passage (shown in Figure 3) should be chosen such that an optimum is found that encourages a significant bending of the streamlines towards the inner liquid 9. In general,  $D_1$  is required to be at least equal to 1.2 times  $D_0$ ,

$$D_1 > 1.2 D_0 .$$

(b) Incident momentum in outer fluid:

To ensure sufficient momentum in the outer fluid at the point where it meets the inner liquid 9, the convergent passage separation between R and P (see Figure 2) must be chosen appropriately. This distance can be defined as the distance between points R and P in Figure 2. For given conditions of pressure and temperature in the outer fluid chamber and outside region, this variable regulates the relative average velocity between the inner liquid 9 and the outer fluid 10 at the point of encounter (inner rim of tube exit indicated by point P' in Figures 2 and 3). For example, a very narrow convergent passage is one in which frictional losses dissipate the outer fluid momentum significantly. Widening such a passage will encourage coupling between outer fluid 10 and inner liquid 9. On the other hand, if the separation between R and P is made too wide, then the effect of efficient atomization is lost, because the fastest speed is encountered then in the discharge orifice, not at the end of the convergent passage.

In general, thus, one desires to have as high a momentum as possible in the outer fluid 10 for a certain amount of outer fluid mass flow (and pressure and temperature conditions). The ratio between momentum and mass fluxes is similar to its average speed (in fact, is very nearly such value when variations in local speed are negligibly small across the convergent passage). The fastest speed is generally obtained in the narrowest part of the outer fluid flow path. Again, if the distance between R and P is too large, then the narrowest part will be at the discharge orifice. Thus, if the distance of R to P is H the largest value of H compatible with this requirement typically is:

$$H_{\max} = \beta D_o$$

10

For axi-symmetric configurations,  $\beta$  equals 0.25; while for planar-two dimensional configurations,  $\beta$  equals 0.5.

On the other hand, H must be large enough to preclude excessive friction between the outer fluid and the convergent passage walls that can slow down the flow and waste pressure energy (stagnation enthalpy) into heat (internal energy). An approximate guiding principle is that H should be greater than  $H_{\min}$ , defined as a few times the thickness of the viscous boundary layer  $\delta_L$  that develops inside the outer fluid 10 in its acceleration through the convergent passage:

$$H_{\min} \sim \lambda \delta_L$$

20

$$\lambda \sim 1 \text{ to } 10$$

The thickness of the boundary layer at point P' (Figure 2) for the case when the outer fluid is near the speed of sound is approximately given by the following expression:

$$\delta_L = (L \mu_2 / (\rho_2 P_{o2})^{0.5})^{0.5}$$

25

Here  $\mu_2$  is the dynamic viscosity coefficient of the outer fluid 10,  $\rho_2$  is its density, and  $P_{o2}$  is the pressure of the outer fluid 10 in the upstream chamber.  $\lambda$  is a numerical factor, which generally is between 1 and 10. L is the length of the convergent passage (Figure 3)

$$L = 0.5 (D_1 - D_t) / \sin(\beta)$$

30

rates used for violent focusing, a small degree of wetting has indeed been detected, but is associated with an insignificant fraction of the inner liquid.)

(d) Vortex breakdown:

5 A theoretical model based on the existence of a vortex cell near the region of breakup is proposed to explain the effectiveness of atomization obtained by the present invention in the case of axi-symmetric geometries. In such cases, it is hypothesized that the strong radial forces provided by the outer fluid flow between the orifice body and the liquid dispenser (a cylindrical tube in its simplest form) result in a violent swirl in the outer fluid  
10 (Shtern and Hussain 1999). The swirling motion results in a vortex which breaks down near the region of breakup. Such breakdown is the centrifugal explosion of the fluid streamlines due to their rapid spinning motion. The entrained particles and filaments of the inner liquid are spun away and dispersed before they get a chance to coalesce (two or more particles forming one). The benefits of vortex breakdown in promoting liquid breakup and drop  
15 dispersion have previously been reported (Hopfinger and Lasheras 1996; Lasheras et al. 1998). In the new invention any swirling of the outer fluid is not created upstream by means of swirling vanes or other shapes of the atomizer body. Instead, the swirling is induced locally by the strong converging motions forced by the very simple geometry of the atomizer.

20

(e) Gas sonic speeds and shock waves:

Sonic speeds and shock waves take place when the outer fluid is a gas. In all tests to date using that configuration, the pressure drop across the atomizer was such that the gas attained sonic and supersonic speeds. Under these conditions shock waves are also expected  
25 to be present.

Characteristics of supersonic flow such as shock waves may improve atomization. However, such are not believed to be required.

Unique characteristics of the present invention include: (f) High frequency of droplet generation, (g) Low requirements on liquid pressure, (h) Low sensitivity of drop size

These expressions neglect the presence of liquid in the discharge orifice, or the possibility of swirling in the flow. Therefore, the equations provided above should be considered as approximate guides, e.g.  $\pm 30\%$  error factors.

5 (c) Flow-focusing of the inner liquid:

In the presence of airflow, the inner liquid 9 coming out of the inner tube 5 gets funnel-shaped into a jet that gets thinner as it flows downstream. The jet can have a variety of different configurations, e.g. a circular cross-section, or a flat planar one. Any configuration can be used which provides flows through the center of the discharge orifice 7, and can become much thinner as it enters the discharge orifice 7 than at the exit 6 of the inner tube 5. This phenomenon has previously been termed "flow-focusing" (see WO 99/31019 published June 24, 1999). The forces responsible for the shaping of the inner liquid 9 are believed to arise from the pressure gradients that set within the outer fluid 10 as it flows through the discharge orifice 7. For example, in axi-symmetric configurations, a round inner liquid jet is expected to attain a diameter  $d_j$  determined by the  $1/2$  power law with liquid flow rate  $Q$  (in volume per unit of time, e.g. cubic meter per second; Gañán-Calvo A. M., 1998):

$$d_j \sim (8\rho_l / (\pi^2 \Delta P_g))^{1/4} Q^{1/2}$$

20  $\rho_l$  is the inner liquid density,  $\pi$  is pi, and  $\Delta P_g$  is the pressure drop in the outer fluid between the upstream value and the value at the point where  $d_j$  is taken and  $\sim$  means approximately equal to with about a  $\pm 10\%$  error margin. This equation will be herein referred to as the "flow-focusing" formula and only applies for a uniform velocity distribution along the inner liquid jet radius.

25 A notable consequence of flow-focusing is that the inner liquid is stabilized towards the center of the discharge orifice. For example, in one of the preferred device embodiments (Figure 5), the exit of both the inner tube 5 and the chamber 2 at point 7 were of equal diameter. However, in all the tests done the inner liquid 9 was observed to flow through the center of the discharge orifice without impacting or wetting its side walls. (Due to the random nature of the drop trajectories under conditions of very high inner liquid flow

30

to inner liquid flow rate, (i) Little apparent effect of atomizer size on droplet size. These characteristics are described further below.

(f) High frequency of droplet generation:

5           When the outer fluid is a gas and the inner fluid a liquid, the data demonstrate that the droplets are much smaller than predicted from the spontaneous capillary breakup, such as Rayleigh breakup in axi-symmetric configurations; (Rayleigh 1882) of an inner liquid column of size  $d_j$  equal to that predicted by the flow-focusing formula discussed earlier. Or, what is the same, for given values of the liquid properties and operational variables, the final  
10 size of the droplets is many times smaller than the flow-focusing diameter  $d_j$  discussed earlier. As a result, the frequency of droplet production is much higher than predicted by spontaneous capillary breakup of the flow focused jet. Accordingly, particles formed via the method described here are substantially smaller (e.g. 1/2 the size or less or 1/20 the size or less) than would be obtained due to spontaneous capillary break-up of the stream exiting the  
15 tube 5 and chamber 2. (See Figure 7)

(g) Low requirements on liquid pressure:

          The inner liquid 9 does not have to be pushed out of its inner tube 5 with a sufficiently high pressure capable of maintaining a stable liquid jet in the absence of outer  
20 fluid flow and solid surfaces in its way. It is not necessary for the inner liquid to form a stable microjet structure. Further, pre-existent inner liquid jet structure coming directly out of the exit opening 6 is not required because, as explained in (c), the liquid meniscus is focused by the action of the outer fluid pressure forces.

25 (h) Low sensitivity of drop size to inner liquid flow rate:

          In the cases tested thus far, a low sensitivity of droplet size on flow rate has been observed. The dependence is close to a power law with exponent 1/5 of the liquid flow rate.

30

(i) Small apparent effect of atomizer size:

Based on the experimental data available thus far (reported later herein), the drop size dependence with inner liquid flow rate, outer fluid pressure and inner liquid physical properties does not seem to involve any variables characterizing the size of the atomizer.

5 (See the EXAMPLES.) However, under certain conditions of operation, for example at high flow rates that lead to a large fraction of the discharge orifice occupied by the liquid, one would expect certain dependence.

### EXAMPLES

10 The following examples are put forth so as to provide those of ordinary skill in the art with a complete disclosure and description of how to make and use the present invention, and are not intended to limit the scope of what the inventors regard as their invention nor are they intended to represent that the experiments below are all or the only experiments performed. Efforts have been made to ensure accuracy with respect to numbers used (*e.g.*  
15 amounts, temperature, etc.) but some experimental errors and deviations should be accounted for. Unless indicated otherwise, parts are parts by weight, molecular weight is weight average molecular weight, temperature is in degrees Centigrade.

Figures 6-9 show results for aerosols produced by methods of the present invention using dry air and dry nitrogen as outer fluids 10, and a range of liquids as inner  
20 fluids 9: distilled water, 2-propanol, 20 % (v/v) by volume of ethanol in water ("20%EtOH"), and 0.1% weight in volume (w/v) Polysorbate-20 in distilled de-ionized water ("0.1%Tween"). Tests were performed in four separate experiments with different atomizers. The atomizers were of an axi-symmetric type and had dimensions as specified below in Table A.

25 The droplet size was determined by phase Doppler anemometry (Lefebvre 1989; Bayvel and Orzechowski 1993) along the axis of the aerosol plume a few centimeters downstream from the exit of the atomizer. This measurement technique led to notoriously low rates of validated counts, i.e. low rates of detected light pulses ("bursts"). This problem appears to result from a combination of high droplet concentrations and high velocities.  
30 Validation count rates lower than 50% have been excluded from the sets of data presented



here. As a consequence, all of the droplet size measurements in experiments 3 and 4 with  
 were excluded from the graphs. Nevertheless, atomizer dimensions have been included in  
 table A to indicate that stable aerosols were obtained in a third and fourth experiment with an  
 atomizer of similar characteristics as in experiment 2, but otherwise of a very different  
 5 design.

TABLE A

Atomizer geometric dimensions (in micron unless indicated) used in the  
 experiments (refer to figure for key); typical tolerance +/-15%, ( $\alpha=0$  degrees;  $\beta=90$  degrees)

Experiment	Do	Dt	D1	H	T	$\phi$ , degrees	$\theta$ , degrees
1	62	50	90	19	50	13 +/-7	60
2	200	200	400	35	75	0	0
3	200	200	400	50	75	0	0
4	200	200	400	50-80	75	0	0

15

Figure 6 is a graph of the volume median diameter (VMD) vs the liquid supply  
 flow rate for four different liquids.

In Figure 7 the volume median diameter and liquid flow rates have been  
 20 non-dimensionalized using similar variables to those identified in the flow-focusing  
 literature (Gañán-Calvo 1998),  $d_o$  and  $Q_o$ :

$$d_o = \sigma / \Delta P_g$$

and

$$25 \quad Q_o = (\sigma^4 / (\rho_l \Delta P_g^3))^{1/2}$$

where  $\sigma$  is the interfacial tension of the liquid-gas interface (newton/meter). However, the  
 definition of the pressure drop  $\Delta P_g$  used here is based not on the upstream (stagnation) and  
 downstream (ambient) values of the pressure, but on the upstream value  $P_o$  and the value  $P^*$   
 30 at the sonic point. The sonic pressure was computed using the well-known isentropic  
 expression:

$$P^* = P_o (2/(k+1))^{k/(k-1)}$$

where  $k$  is the heat capacity ratio of the gas (equal to 1.4 for dry air and dry nitrogen; White 1994). Therefore

$$\Delta P_g = P_o - P^* = P_o (1 - (2/(k+1))^{k/(k-1)})$$

5

Thus, for both dry air and nitrogen,

$$\Delta P_g = 0.4717 P_o$$

10 In these experiments  $P_o$  was varied between 200 kPa and 700 kPa.

The best power law fit to the available data (Figure 7) is:

$$\text{VMD} / d_o = 5.60 (Q/Q_o)^{0.208}$$

15 Figure 8 graphs the new fit characteristic of the new method together with the one which would correspond to the Rayleigh breakup of a flow focused jet at the same conditions of liquid properties, flow rate, and gas pressure (thus equal  $d_o$ ,  $Q$ , and  $Q_o$ ). The results shown in Figure 8 are based on the theoretical assumption that Rayleigh breakup of a flow-focused jet would result in droplets of uniform diameter (VMD) equal to 1.89 times the jet diameter  
20 (Brodkey 1995). Applying the equation for the jet diameter given earlier leads to:

$$\text{VMD} = 1.89 (8\rho_l / (\pi^2 \Delta P_g))^{1/4} Q^{1/2}$$

This expression can be cast into dimensionless form using the definitions of  $d_o$  and  $Q_o$ :

25

$$\text{VMD} / d_o = 1.89 (8/\pi^2)^{1/4} (Q/Q_o)^{1/2}$$

In Figure 8 the "Rayleigh breakup" line has been represented between the limits believed to occur in reality. If this expression could be extrapolated to higher  $Q/Q_o$  values, it  
30 would predict larger drop sizes at equal conditions of  $Q/Q_o$  and  $d_o$ . But, more importantly,

because the dependence with  $Q/Q_0$  is much less pronounced than for flow-focused jets, the range of liquid flow rates over which a certain band of desired drop sizes can be generated is much wider than from Rayleigh breakup of flow-focused jets. These conclusions should apply as well when a comparison is being made to non-Rayleigh breakup of flow-focused jets, provided the droplet diameters become similar to the jet diameter.

Another notable result is that data from dissimilar atomizers seems to follow the same scaling law. In other words, based on currently available data, the scaling law appears to be relatively insensitive to the scale of the atomizer.

The proposed atomization system obviously requires delivery of the liquid to be atomized and the gas to be used in the resulting spray. Both should be fed at a rate ensuring that the system lies within the desired parameter window. Multiplexing is effective when the flow-rates needed exceed those obtained for an individual cell. More specifically, a plurality of feeding sources or holes therein forming tubes may be used to increase the rate at which aerosols are created. The flow-rates used should also ensure the mass ratio between the flows is compatible with the specifications of each application.

The gas and liquid can be dispensed by any type of continuous delivery system (e.g. a compressor or a pressurized tank the former and a volumetric pump or a pressurized bottle the latter). If multiplexing is needed, the liquid flow-rate should be as uniform as possible among cells; this may entail propulsion through several capillary needles, porous media or any other medium capable of distributing a uniform flow among different feeding points.

Although a single liquid supply means is shown in Figures 1-5 it, of course, is possible to produce a device with a plurality of feeding members where each feeding member feeds fluid to an array of outlet orifices in a single surrounding pressure chamber. In addition, the liquid supply means may be planar with grooves therein, but need not be strictly planar, and may be a curved feeding device comprised of two surfaces that maintain approximately the same spatial distance between the two pieces of the liquid supply means. Such curved devices may have any level of curvature, e.g. circular, semicircular, elliptical, hemi-elliptical, etc.

30

## DRUG DELIVERY DEVICE

A device of the invention may be used to provide particles for drug delivery, e.g. the pulmonary delivery of aerosolized pharmaceutical compositions. The device would produce aerosolized particles of a pharmaceutically active drug for delivery to a patient by inhalation. The device is comprised of a liquid feeding source such as a channel to which formulation is added at one end and expelled through an exit opening. The feeding channel is surrounded by a pressurized chamber into which gas is fed and out of which gas is expelled from an opening. The opening from which the gas is expelled is positioned directly in front of the flow path of liquid expelled from the feeding channel. Various parameters are adjusted so that pressurized gas surrounds liquid flowing out of the feeding channel in a manner so as to reduce the dimension of the flow which is then broken up on leaving the chamber. The aerosolized particles are inhaled into a patient's lungs and thereafter reach the patient's circulatory system.

15

## PRODUCTION OF DRY PARTICLES

The method of the invention is also applicable in the mass production of dry particles. Such particles are useful in providing highly dispersible dry pharmaceutical particles containing a drug suitable for a drug delivery system, e.g. implants, injectables or pulmonary delivery. The particles formed of pharmaceutical are particularly useful in a dry powder inhaler due to the small size of the particles (e.g. 1-5 microns in aerodynamic diameter) and conformity of size (e.g. 3 to 30% difference in diameter) from particle to particle. Such particles should improve dosage by providing accurate and precise amounts of dispersible particles to a patient in need of treatment. Dry particles are also useful because they may serve as a particle size standard in numerous applications.

25

For the formation of dry particles, the first fluid is preferably a liquid, and the second fluid is preferably a gas, although two liquids may also be used provided they are generally immiscible. Atomized particles are produced within a desired size range (e.g., 1 micron to about 5 microns). The first fluid liquid is preferably a solution containing a high concentration of solute. Alternatively, the first fluid liquid is a suspension containing a uniform concentration of suspended matter. In either case, the liquid quickly evaporates

30

upon atomization (due to the small size of the particles formed) to leave very small dry particles.

#### FUEL INJECTION APPARATUS

5           The device of the invention is useful to introduce fuel into internal combustion engines by functioning as a fuel injection nozzle, which introduces a fine spray of aerosolized fuel into the combustion chamber of the engine. The fuel injection nozzle has a unique fuel delivery system with a pressure chamber and a fuel source. Atomized fuel particles within a desired size range (e.g., 5 micron to about 500 microns, and preferably  
10 between 10 and 100 microns) are produced from a liquid fuel formulation provided via a fuel supply opening. Different size particles of fuel may be required for different engines. The fuel may be provided in any desired manner, e.g., forced through a channel of a feeding needle and expelled out of an exit opening of the needle. Simultaneously, a second fluid, e.g. air, contained in a pressure chamber which surrounds at least the area where the  
15 formulation is provided (e.g., surrounds the exit opening of the needle) is forced out of an opening positioned in front of the flow path of the provided fuel (e.g. in front of the fuel expelled from the feeding needle). Various parameters are adjusted to obtain a fuel-fluid interface and an aerosol of the fuel, which allow formation of atomized fuel particles on exiting the opening of the pressurized chamber.

20           Fuel injectors of the invention have two significant advantages over prior injectors. First, fuel generally does not contact the periphery of the exit orifice from which it is emitted because the fuel stream is surrounded by a gas (e.g. air) which flows into the exit orifice. Thus, clogging of the orifice is eliminated or substantially reduced. In addition, formation of carbon deposits around the orifice exit is also substantially reduced or  
25 eliminated. Second, the fuel exits the orifice and forms very small particles which may be substantially uniform in size, thereby allowing faster and more controlled combustion of the fuel.

## MICROFABRICATION

Molecular assembly presents a 'bottom-up' approach to the fabrication of objects specified with incredible precision. Molecular assembly includes construction of objects using tiny assembly components, which can be arranged using techniques such as  
5 microscopy, e.g. scanning electron microspray. Molecular self-assembly is a related strategy in chemical synthesis, with the potential of generating nonbiological structures with dimensions as small as 1 to 100 nanometers, and having molecular weights of  $10^4$  to  $10^{10}$  daltons. Microelectro-deposition and microetching can also be used in microfabrication of objects having distinct, patterned surfaces.

10 Atomized particles within a desired size range (e.g., 0.001 micron to about 0.5 microns) can be produced to serve as assembly components to serve as building blocks for the microfabrication of objects, or may serve as templates for the self-assembly of monolayers for microassembly of objects. In addition, the method of the invention can employ an atomizate to etch configurations and/or patterns onto the surface of an object by  
15 removing a selected portion of the surface.

The instant invention is shown and described herein in a manner which is considered to be the most practical and preferred embodiments. It is recognized, however, that departures may be made therefrom which are within the scope of the invention and that  
20 obvious modifications will occur to one skilled in the art upon reading this disclosure.

What is claimed is:

1. A method, comprising the steps of:  
5 forcing a liquid out of an exit opening of a liquid supply means;  
forcing a fluid into a pressure chamber which surrounds the exit opening of the liquid supply means, the fluid being provided in a manner such that the fluid: (a) focuses liquid exiting the exit opening to a stream having dimensions smaller than that of the exit opening; (b) provides momentum to and interacts with the liquid exiting the liquid supply  
10 means; (c) destabilizes the liquid so as to form particles of the liquid wherein the mean dimensions of particles formed is less than the dimensions of the focused liquid stream; and (d) carries the liquid stream out of the pressure chamber.
2. The method of claim 1, wherein the fluid forced into the pressure chamber is  
15 a gas and wherein (e) the gas rapidly converges toward the liquid along streamlines that form an angle of  $45^\circ$  or greater with respect to the liquid.
3. The method of claim 1, wherein the fluid forced into the pressure chamber is  
a liquid which is immiscible in the liquid in the liquid supply means.  
20
4. The method of claim 1, wherein the liquid exiting the liquid supply means is focused to dimensions which are  $1/2$  or less the dimensions of the liquid supply means.
5. The method of claim 2, wherein particles formed have  $1/10$  or less the mean  
25 volume of the particles expected to be formed by normal Rayleigh breakup and the gas converges on the liquid at an angle of from  $45^\circ$  to less than  $90^\circ$ .
6. The method of claim 2, wherein the particles formed are sufficiently small  
that their surface tension forces substantially match the amplitude of pressure fluctuations  
30 created by the liquid and gas exiting the pressure chamber.

7. A method of creating an aerosol, the method comprising the steps of forcing a liquid through a feeding tube and out of an exit opening of the feeding tube wherein the exit opening of the feeding tube is positioned such that the liquid flowing out of the tube flows toward and out of an exit orifice of a chamber surrounding the exit opening of the feeding tube;

5

forcing a gas into the chamber and out of the exit orifice of the chamber;

wherein the exit opening of the feeding tube has a diameter in the range of about 5 to about 10,000 microns and the exit opening of the tube is positioned at a distance in a range of from about 5 to about 10,000 microns from an entrance point of the exit orifice.

10

8. A method of creating an aerosol, comprising the steps of:

forcing a liquid out of an exit opening of a liquid supply means to form a liquid stream;

forcing a gas into a chamber and out of an exit orifice aligned with a flow path of liquid having the exit opening whereby the liquid stream is focused by the gas to dimensions smaller than dimensions of the exit opening;

15

wherein the exit opening and exit orifice are positioned such that particles formed outside the exit orifice have a size determined by the relationship between the particle surface tension and the amplitude of turbulent pressure fluctuation outside the chamber and further wherein that relationship is such that the particles have dimensions smaller than dimensions of the focused liquid stream.

20

9. A method, comprising the steps of:

forcing a liquid out of an exit opening of a liquid supply means;

25

forcing a gas into a pressure chamber and out of an exit orifice of the chamber;

causing the gas to converge against the liquid exiting the liquid supply means thereby (a) causing the liquid to assume dimensions smaller than dimensions of the exit opening of the liquid supply means; (b) creating a violent interaction between the liquid and the gas; (c) carrying the liquid away from the exit orifice of the pressure chamber; and (d)



resulting in the liquid forming particles which are smaller in size than expected based on spontaneous capillary breakup of the assumed smaller dimensions of the liquid.

10. The method of claim 1, wherein the exit opening of the liquid supply means  
5 has an opening with a cross-sectional configuration selected from the group consisting of a circle, an oval, a square and an elongated rectangular slit.

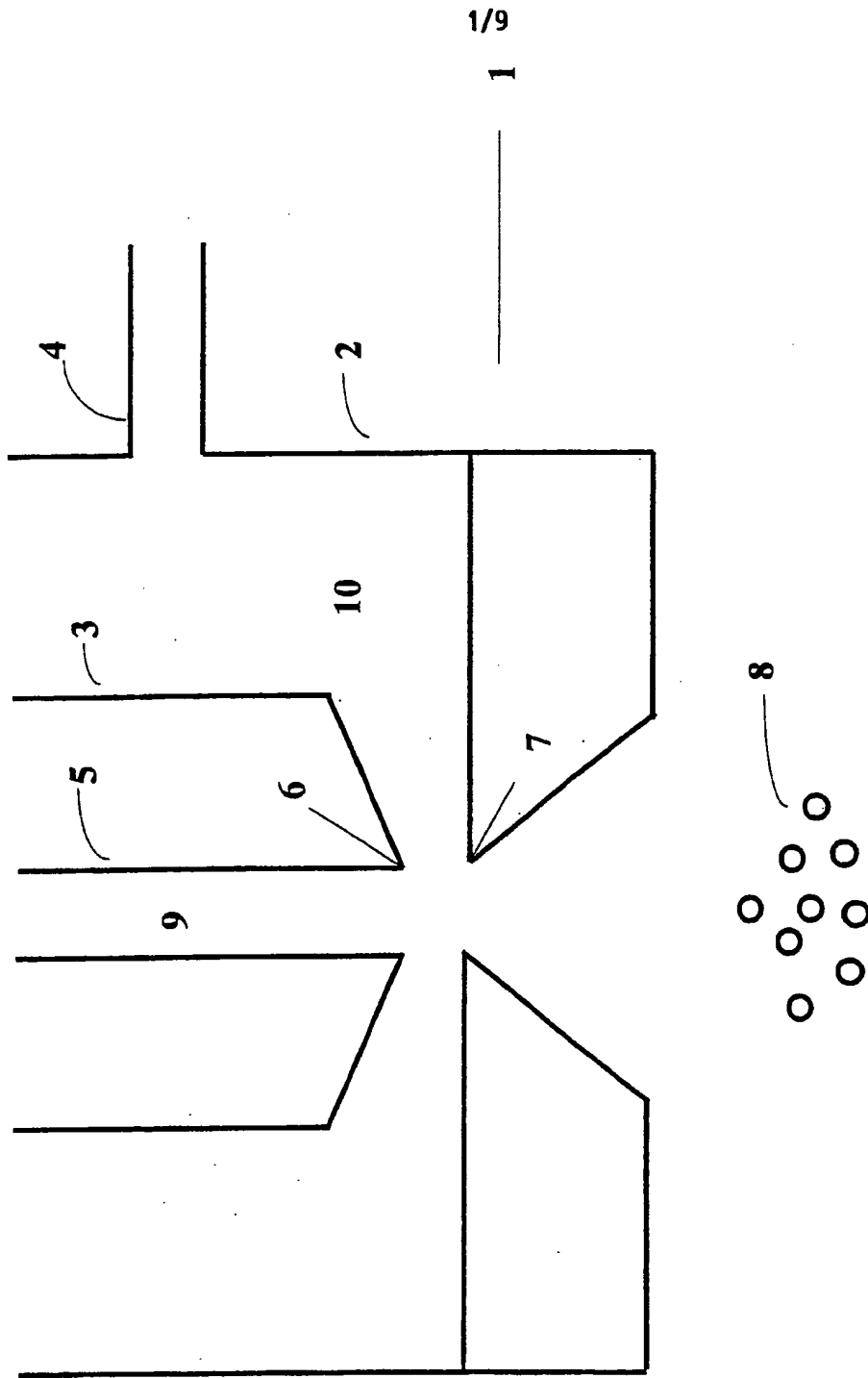

Figure 1

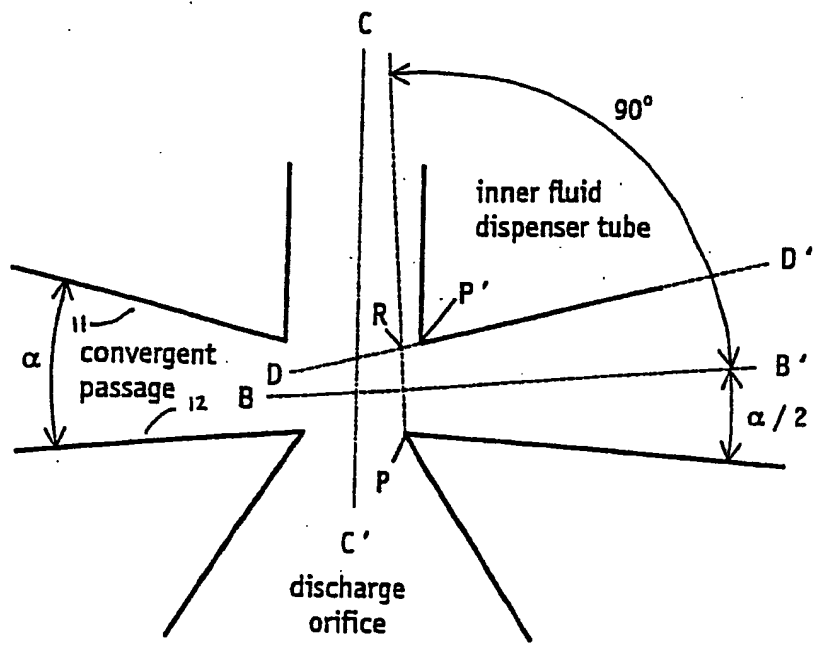

Figure 2

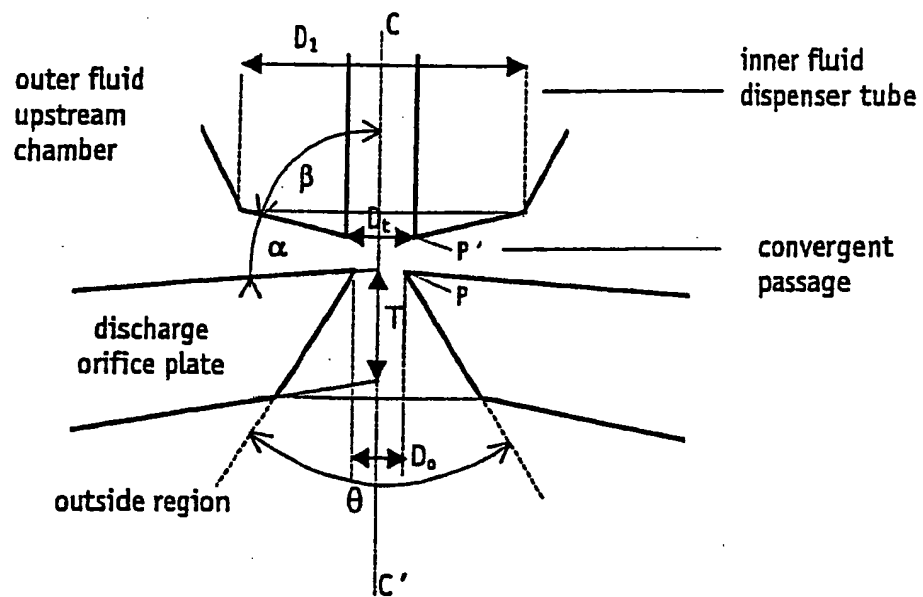

Figure 3

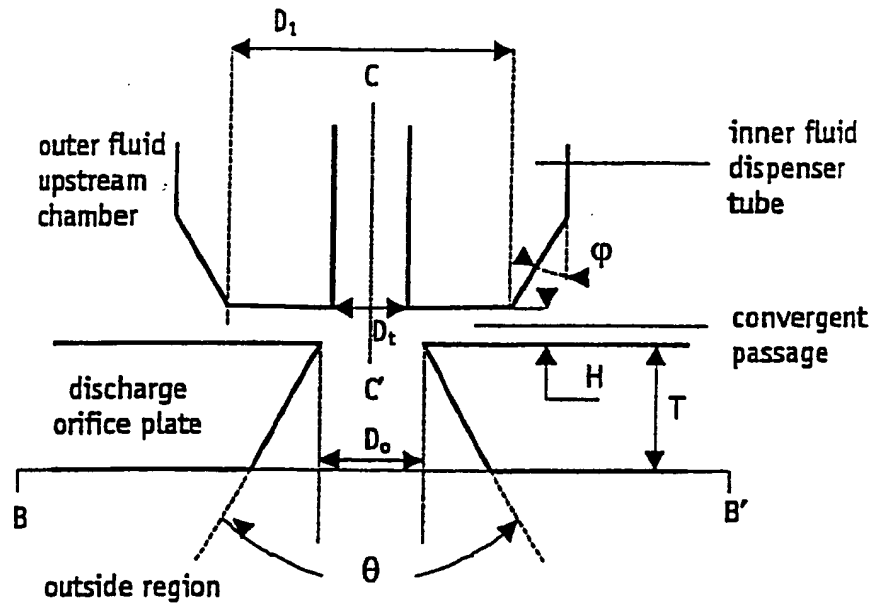

Figure 4

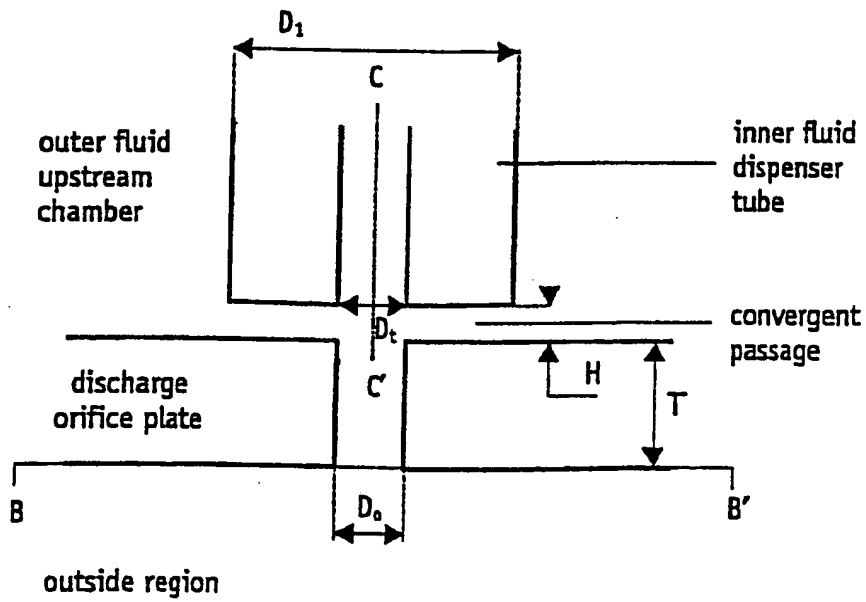

Figure 5

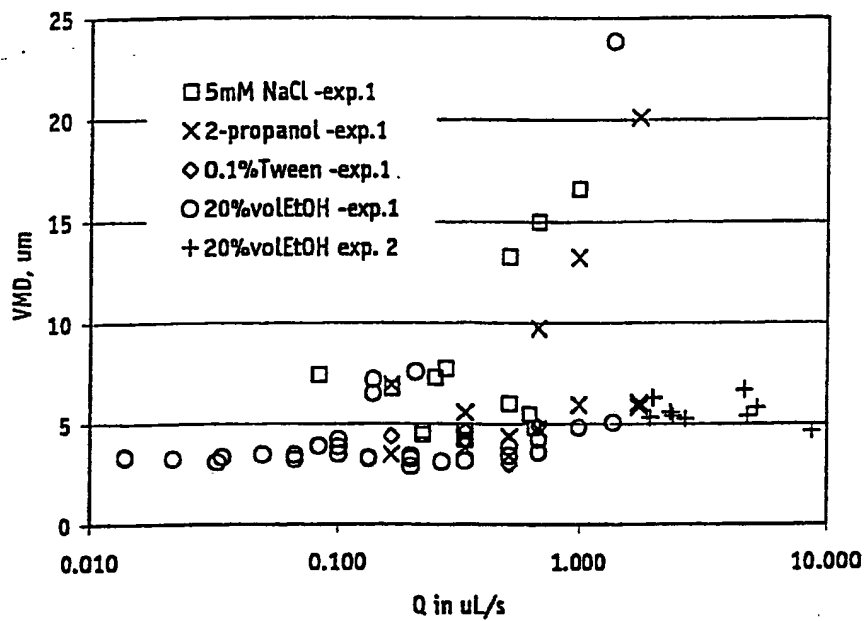

Figure 6

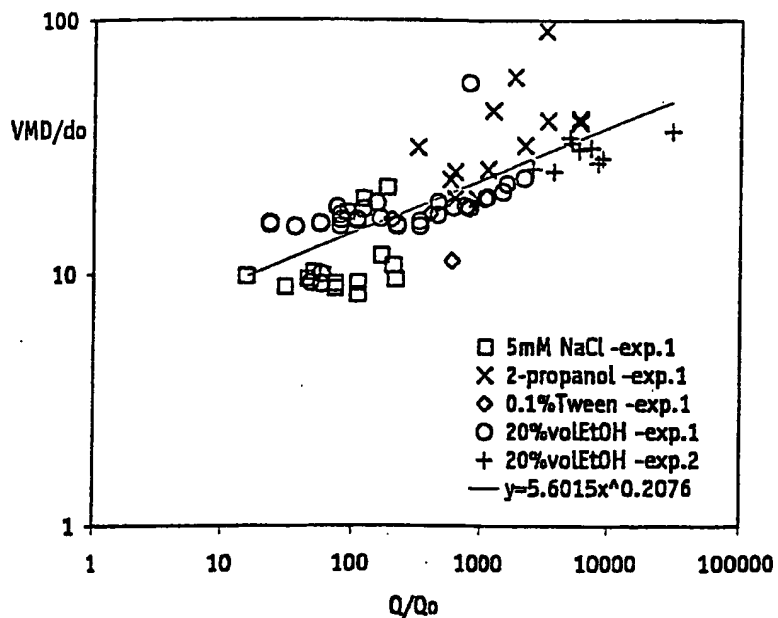

Figure 7



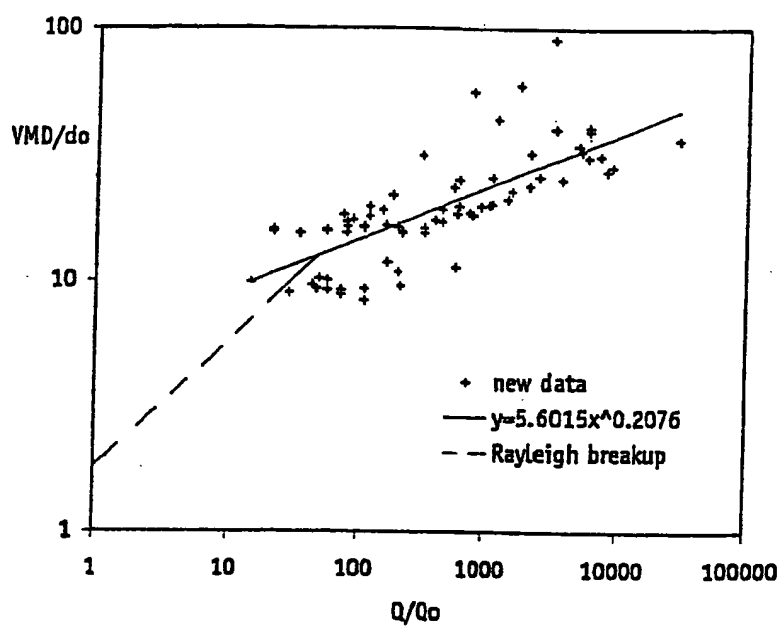

Figure 8

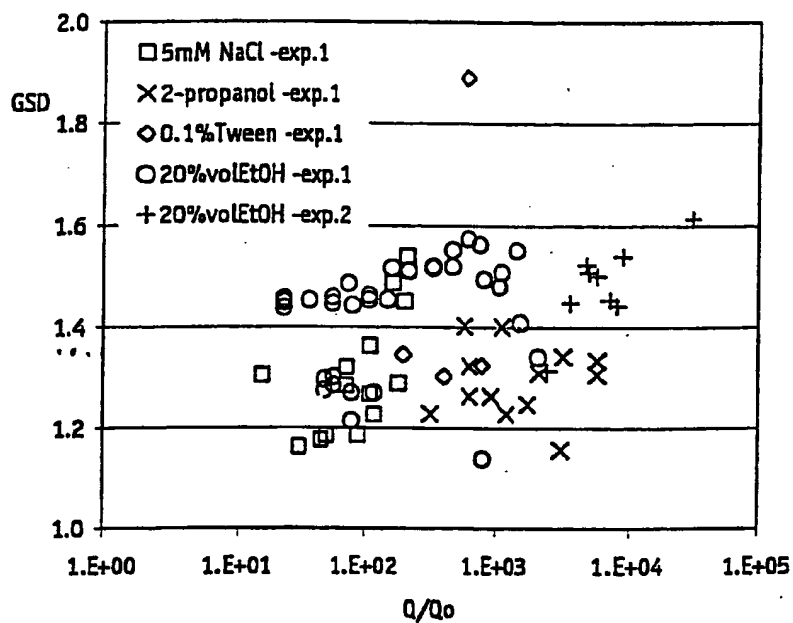

Figure 9

INTERNATIONAL SEARCH REPORT

International application No.  
PCT/US00/15931

<b>A. CLASSIFICATION OF SUBJECT MATTER</b> IPC(7) : B05B 7/00 US CL : 239/8, 10 According to International Patent Classification (IPC) or to both national classification and IPC		
<b>B. FIELDS SEARCHED</b> Minimum documentation searched (classification system followed by classification symbols) U.S. : 239/8-10, 433, 423, 424 Documentation searched other than minimum documentation to the extent that such documents are included in the fields searched Electronic data base consulted during the international search (name of data base and, where practicable, search terms used) EAST-BRS search term aerosol		
<b>C. DOCUMENTS CONSIDERED TO BE RELEVANT</b>		
Category*	Citation of document, with indication, where appropriate, of the relevant passages	Relevant to claim No.
A	US 5,868,322 A (LOUCKS, JR. et al.) 09 February 1999, see entire document.	1-10
A	US 5,884,846 A (TAN) 23 March 1999, see entire document.	1-10
<input type="checkbox"/> Further documents are listed in the continuation of Box C. <input type="checkbox"/> See patent family annex.		
* Special categories of cited documents:	*T*	later document published after the international filing date or priority date and not in conflict with the application but cited to understand the principle or theory underlying the invention
*A* document defining the general state of the art which is not considered to be of particular relevance	*X*	document of particular relevance; the claimed invention cannot be considered novel or cannot be considered to involve an inventive step when the document is taken alone
*E* earlier document published on or after the international filing date	*Y*	document of particular relevance; the claimed invention cannot be considered to involve an inventive step when the document is combined with one or more other such documents, such combination being obvious to a person skilled in the art
*L* document which may throw doubts on priority claim(s) or which is cited to establish the publication date of another citation or other special reason (as specified)	*A*	document member of the same patent family
*O* document referring to an oral disclosure, use, exhibition or other means		
*P* document published prior to the international filing date but later than the priority date claimed		
Date of the actual completion of the international search 26 JULY 2000	Date of mailing of the international search report 24 AUG 2000	
Name and mailing address of the ISA/US Commissioner of Patents and Trademarks Box PCT Washington, D.C. 20231 Facsimile No. (703) 305-3230	Authorized officer <i>Stacia Cadmus</i> LESLEY D. MORRIS Telephone No. (703) 308-0629	